

JOINERY MAINTENANCE TO
MODERN REPAIR

FURNITURE, WINDOWS,
KITCHEN UNITS, DOORS

GLASS CUT TO SIZE

PAINTING & DECORATING

mini van & pick up



MinipassionMini.com



NOW MORE THAN EVER IT'S THE OBVIOUS CHOICE

The big-hearted quarter-ton Mini Van might have been specially designed for today's world of rising transport costs—a positive way to keep these costs down, without lowering your standards of service or losing Company prestige in any way.

The ubiquitous Mini Van gives a nominal 5 cwt carrying capacity equal to many more expensive vehicles. Yet its incredibly compact outside dimensions—bumper to bumper is under 11 feet!—conceals an interior capacity of 46 cu. ft. (plus an extra 12 cu. ft. beside the driver if a passenger seat isn't fitted).

The Mini's loadspace floor is just under 1½ ft. from the ground, which most people find a comfortable and convenient height. The Van's loadspace is reached either through the wide-opening double doors at the rear or from the driving compartment. It's small enough to squeeze through traffic gaps where more cumbersome vehicles have to idle in the queue. And it will wriggle into parking spaces the others haven't even recognized.

You'll save real money on service and repairs, too. First, because the entire Mini technological package (run your eye down the specification) is so well-proved that its reliability is legend. Second, because there are nearly 2,500 well-equipped Austin Morris service outlets throughout Britain, all carrying comprehensive stocks of Unipart spares and accessories. But there's more to the Mini Van than cost-efficiency, important though this is in these difficult times. There's that other vital consideration, driver appeal.

Most people like driving a Mini—count them on the road—and, unlike some car derivatives, the Mini Van retains all the safety, precision, nippiness and sheer drivability of the saloon car from which it is derived.

Add up the advantages for yourself. Then compare everything the Mini Van offers with the claims of its bulkier competitors. You'll conclude that now, more than ever before, this honest, likeable vehicle is the obvious choice.



MinipassionMini.com

**mini
van**



MinipassionMini.com



mini pick-up



COST-CUTTING TOOL OF EVERY TRADE

It's simply the most versatile member of the whole Mini family, with a 26 $\frac{3}{4}$ cu. ft. body ready and willing to take on the everyday transport jobs of a thousand different trades and businesses. A single-piece fold-down tailgate gives access to the Pick-up's load-space, whilst light articles are easily lifted over the waist-level sides.

Like the Mini Van, it's incredibly thrifty, with similarly low maintenance costs, returning around 40 miles to the gallon under typical operating conditions. The famous transversely-mounted 848 cc, four-cylinder engine makes light of heavy loads and gives you the kind of brisk acceleration you need to thread your way through traffic snarls. As for parking, the tiniest space takes on new dimensions when you're at the wheel of a Mini. For off-the-road work, this robust Pick-up is in a class of its own, with front-wheel drive to get you out of sticky situations and independent rubber-unit suspension to iron out the roughest ground.

Yet, rugged as it is, this remarkable vehicle also retains all the driving precision and charm of the Mini saloon car, with simple and clean instrumentation, comfort, good visibility and useful stowage space for a mass of business papers and oddments. Small wonder the Mini Pick-up is a favourite tool of every trade.



MinipassionMini.com

MinipassionMini.com

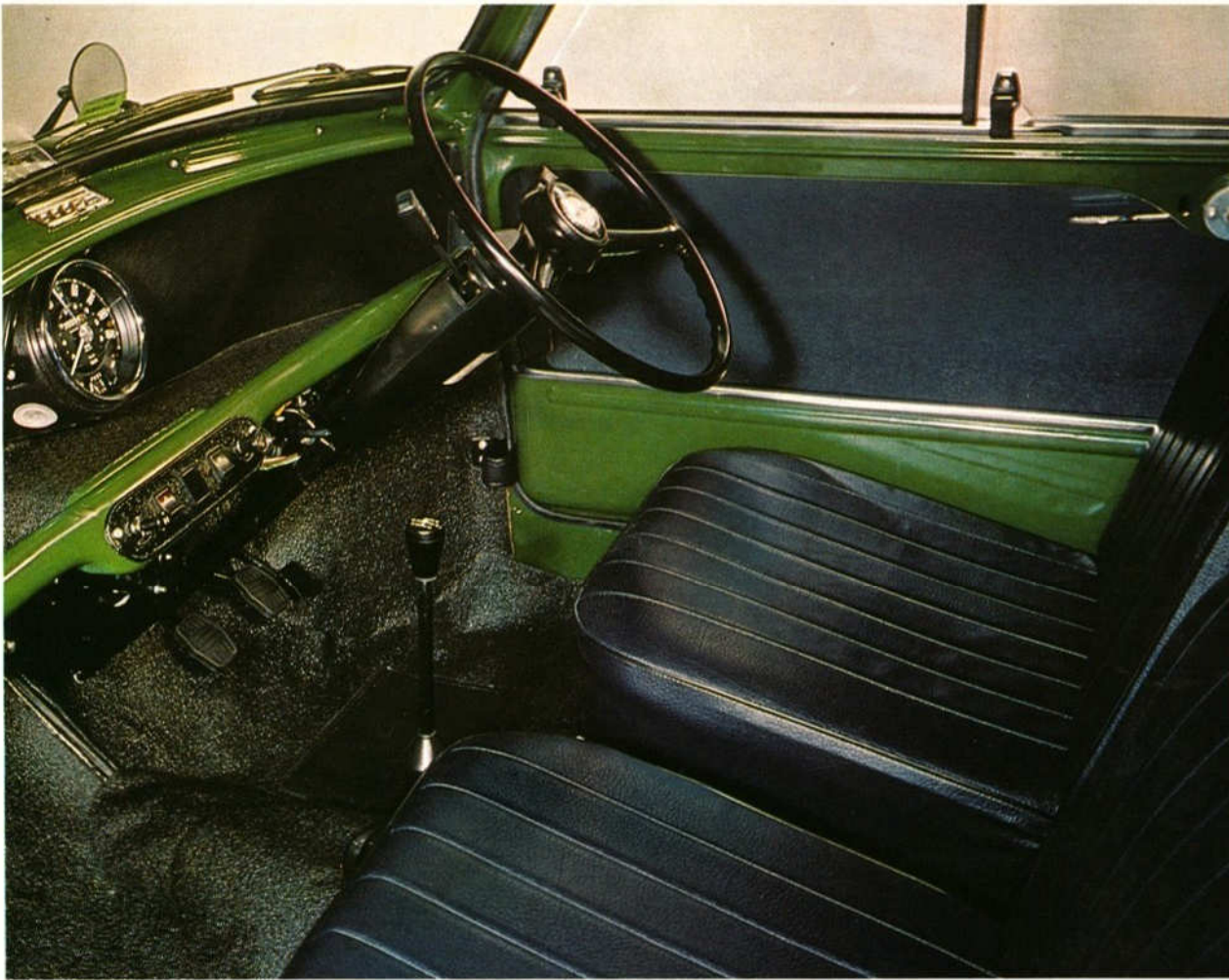

Van or Pick-up, you'll enjoy saloon car comfort and driving precision. Controls are light, positive and exactly where you want them to be. A steering column lock is fitted as standard and there are warning lights for flashers/hazard lamps, headlamp high beam, low oil pressure and no charge.

The transverse engine layout pioneered by Austin Morris and copied by the world, is still the standard by which the others are judged. Whether your choice is the 848 cc or the optional 998 cc engine, there is ample power for Van or Pick-up in fully laden condition.

In unit with the hydraulically actuated clutch and 4-speed, all-synchromesh gearbox, either power pack operates efficiently and economically in typical operating conditions, using 2-star fuel.

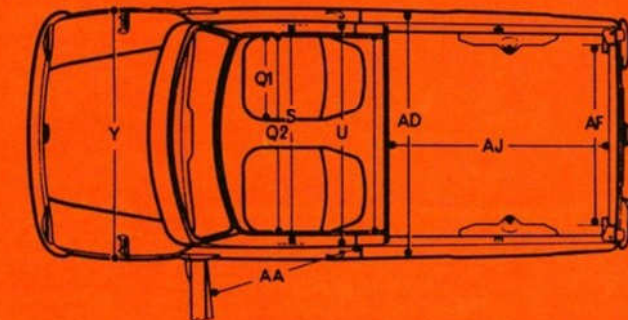
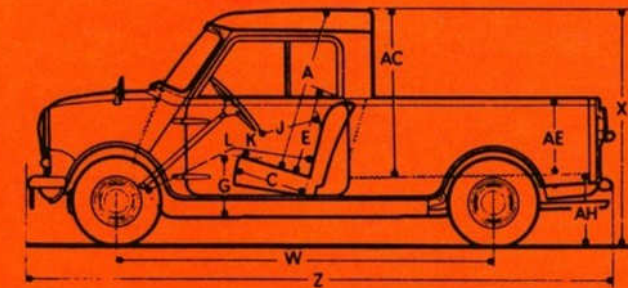
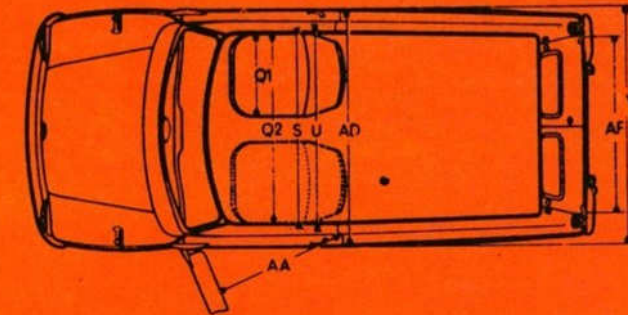
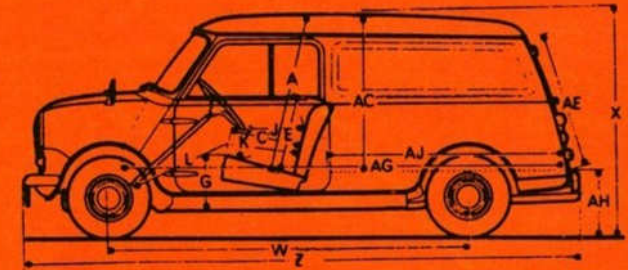

Specifications

		<i>in.</i>	<i>m.</i>
*Seat cushion to roof A	38.0	0.97
*Seat cushion depth C	18.0	0.46
*Seat squab height E	19.0	0.48
*Height of seat cushion G	13.5	0.34
*Steering-wheel to squab—max. J	16.5	0.42
min. J	12.5	0.32
*Steering-wheel to cushion K	6.5	0.17
*Leg room—max. L	43.5	1.10
min. L	41.0	1.04
*Width of single seat Q1	20.0	0.51
*Overall width of seats Q2	43.5	1.10
*Max. seat width at cushion level S	45.5	1.16
*Width over seats at shoulder height U	46.0	1.17
Wheelbase W	84.2	2.14
Overall height X	53.5	1.36
Overall width Y	55.5	1.41
Overall length (Van) Z	129.9	3.30
(Pick-up) Z	130.2	3.31
Door entry width AA	32.0	0.81
Height—body floor to roof (Van) AC	37.25	0.95
(Pick-up) AC	37.0	0.94
Body interior width AD	53.75	1.37
Rear doors opening height (Van) AE	31.75	0.81
Body interior height (Pick-up) AE	17.25	0.44
Rear doors opening width at floor (Van) AF	40.0	1.02
Tailboard opening width (Pick-up) AF	39.2	1.00
Engine bulkhead to rear doors at floor (Van) AG	102.75	2.61
Height of body floor AH	17.5	0.44
Body interior length at floor (Van) AJ	55.0	1.40
(Pick-up) AJ	54.75	1.39
Ground clearance	6.0	0.15

* Approximate measurement

Engine: 4-cylinder, transverse, o.h.v. In unit with clutch, gearbox and final drive.

(848 c.c.) Bore 2.478 in. (62.94 mm.); stroke 2.687 in. (68.25 mm.). Capacity 848 c.c. (51.74 cu. in.). S.U. type HS4 carburetter. †33 b.h.p. at 5,300 r.p.m. Maximum torque 15.5 kgf. m. (39.8 lbf. ft.) at 2,500 r.p.m. Compression ratio 8.3 : 1. Paper-element type air cleaner, with air intake incorporating air temperature control valve. Full flow oil filtration with renewable element. Oil capacity (including filter) 9 pints (5.1 litres).

(998 c.c.—optional at extra cost) Bore 2.543 in. (64.59 mm.); stroke 3.0 in. (76.2 mm.). Capacity 998 c.c. (60.96 cu. in.). S.U. type HS4 carburetter. †39 b.h.p. at 4,750 r.p.m. Maximum torque 17.12 kgf. m. (51.5 lbf. ft.) at 2,000 r.p.m. Compression ratio 8.3 : 1. Paper-element type air cleaner, with air intake incorporating air temperature control valve. Full flow oil filtration with renewable element. Oil capacity (including filter) 9 pints (5.1 litres).

Clutch: Diaphragm-spring, 7.125 in. (0.18 m.) diameter, hydraulically operated.

Gearbox: 4-speed, synchromesh on forward gears with centre-floor gear change. Ratios: 1st 3.53, 2nd 2.22, 3rd 1.43, top 1.00, and reverse 3.54 : 1.

Final Drive: Front-wheel drive, with pre-lubricated universals on open shafts. Ratio 3.76 : 1 (848 c.c.); 3.44 : 1 (998 c.c.).

Steering: Rack and pinion.

Road Wheels: Pressed-steel disc, 145—10 radial-ply tubeless tyres.

Brakes: Hydraulic with 7 in. (0.18 m.) diameter drums all round. Two-leading-shoes at front, leading and trailing at rear.

† DIN 70020

Suspension: Independent all round. Cone rubber springs and telescopic hydraulic dampers.

Electrical: 12-volt system, negative earth, 36-amp. hr. battery. Multi-purpose lever on right-hand of steering-column controls horn, headlamp flasher, dipswitch, and self-cancelling direction indicators. Lever on left-hand of steering-column controls electric windscreen washer and two-speed windscreen wipers with flick-wipe facility. Hazard warning lamps. Combined ignition/starter switch incorporates steering-column lock.

Instruments: Speedometer. Fuel gauge. Warning lamps to show flashers/hazard lamps working, headlamp high-beam, low oil pressure, and no charge.

Bodywork: (Van) All-steel delivery vehicle of unitary construction with hinged cab doors and twin rear doors. Capacity 46 cu. ft. (1.30 m.³); a further 12 cu. ft. (0.34 m.³) is available when the passenger seat is not fitted.

(Pick-up) All-steel delivery vehicle of unitary construction. Integral cab and body with hinged cab doors and hinged tail-board. Capacity (up to waist level) 26.75 cu. ft. (0.76 m.³).

Both models are equipped with screen washer, interior light, recirculatory heater, passenger seat and factory-fitted seat belts.

Optional Extras: 998 c.c. engine with 3.44 : 1 final drive ratio : tilt tubes and cover (Pick-up only).

Export Markets: The specification of this model is correct for the U.K. market at date of printing. Export specifications may differ to suit conditions and regulations of overseas territories. Please check details with your Dealer.

MinipassionMini.com

U.K. PLATING DETAILS (TONS)			
	FRONT AXLE	REAR AXLE	G.V.W.
Van	0.54	0.48	0.94
Pick-up	0.54	0.48	0.94

KERBSIDE WEIGHTS*						
	FRONT AXLE		REAR AXLE		TOTAL	
	lb.	kg.	lb.	kg.	lb.	kg.
Van	836	379	535	243	1371	622
Pick-up	855	387	514	233	1369	621

* Including water, oil, spare wheel, tools, and tank full of petrol.

IMPORTANT NOTICE

British Leyland UK Limited is constantly seeking ways to improve the specification, design and production of its vehicles and alterations take place continually. While every effort is made to produce up to date literature, this Brochure should not be regarded as an infallible guide to current specification, nor does it constitute an offer for the sale of any particular vehicle.

Distributors and Dealers are not agents of British Leyland UK Limited and have absolutely no authority to bind British Leyland UK Limited by any express or implied undertaking or representation.

Leyland Cars



SUPERCOVER

**Even if you never need it,
it's good to know you've got it.**

**Applicable only to vehicles used within
the United Kingdom.**

Every new vehicle detailed in this brochure has Supercover. It's one of the most comprehensive service schemes ever offered in the United Kingdom by any motor vehicle manufacturer.

At each and every stage in their production, vehicles are thoroughly examined by our experts and engineers. In addition, the dealer puts each vehicle through a long and extensive check.

So when you buy your new vehicle from Leyland Cars you can be confident that everything possible has been done to ensure that it is in perfect condition.

Supercover is a very comprehensive package. But if you have any trouble whatsoever, no matter how small, you just contact your dealer. He'll do his best to keep your vehicle in perfect condition.

If you're not 100% satisfied with the service you get, then we provide a special card with every vehicle, which should be sent direct to the Managing Director of Leyland Cars, and he'll make sure the problem is solved quickly and efficiently.

Supercover is a permanent charter for the British motorist. It gives you one more reason for buying from the Leyland Cars range.

 **Leyland Cars**

**BRITISH LEYLAND UK LIMITED
GROSVENOR HOUSE
REDDITCH, WORCS. B97 4DQ**

*Lithographed by The Nuffield Press Limited, Cowley,
Oxford, England. 23/204 (92356) 9/76—100m.*

Publication No. 3145/B



MinipassionMini.com